

**The
Airship “Simon”**

**The
Design and Construction
of a
Radio Controlled Blimp**

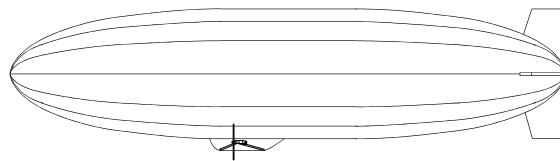

Cyril Lutz

Maurice Rüegg

Cyril Lutz and Maurice Rüegg

The Airship “Simon”

The
Design and Construction
of a
Radio Controlled Blimp

Realgymnasium Rämibühl
8001 Zürich

A Research Project
November 1996 – February 1998

Contents

Acknowledgments	5
Foreword	6
Abstract	7
Nomenclature	7
Abbreviations	7
AIRSHIP DESIGN	8
1. Introduction	9
a) What is an Airship?	9
b) What is “Simon”?	9
2. Buoyancy and Lift	10
a) The Lift Logo	10
b) Static Lift of an Airship	11
c) Temperature and Pressure	12
3. The Envelope	13
a) Dimensions – The Look of a Zeppelin	13
b) Volume, Lifting Force, and Weight	13
4. The Gondola	14
a) Functions	14
b) Form and Dimensions	14
5. Flight Dynamics	14
a) Steering	14
b) Friction and Air Resistance	15
c) Stabilization	16
6. Electronics and Motorization	16
a) Electronics	16
b) Motorization	16
7. Etceteras	17
a) Flight Certification	17
b) Meteorology and Atmospheric Effects	17
THE CONSTRUCTION OF “SIMON”	18
1. First Steps	19
a) Hull Shape	19
b) A Gondola	20
c) Dimensions	20
2. Calculations and Model Construction	21
a) Hull Values	21
b) Calculating Hullparts	23
c) First Models	24

3. Construction of the Main Parts	24
a) A Tilting Axle	24
b) Construction of the Gondola and the Hull	25
c) The Electronics	26
d) The Fins	27
4. First Experiences and Improvements	27
a) Flight Preparations	27
b) Flying a Blimp	27
c) Improvements	27
5. Completion	28
a) Motor Thrust – An Experiment	28
b) Air Resistance – An Approximation	28
c) Helium Recycling	29
APPENDICES	30
Appendix A: Technical Information of “Simon”	31
Appendix B: Hullpart Data	32
Appendix C: Scientific Data Tables	34
Appendix D: The Zeppelins	36
Bibliography	37
Sources for Figures and Tables	39

Acknowledgments

“Failure is an orphan . . . but success has many fathers.”

Due to the ideas and support of a great many people around the two of us, the airship “Simon” has become reality. Their support has helped to solve all problems and leave only solutions.

Special thanks to

Patrick Ehrismann, our teacher and project manager for his general assistance, support and time

The financial issue-solving donator, who would like to stay in the back

Hanspeter Gallmann for some useful devices

The Immark Ltd. for their compressing assistance

Anton Knobel and Paul Oswald, the technicians of the Realgymnasium Rämibühl, for their practical guidance and real life experience

Robert König for his ideas and interest in our problems

André Masson for checking on theoretical flaws

Diego Oppenheim for his sound and pictorial work and his great perseverance

Christian Sommer for making the following understandable

Oskar Wirth for some fast problem solutions

and

Our families and especially Natalie for being there when four hands were just not enough and time was running just too fast.

Foreword

It all started in November 1996, when we decided to build an “air-something” because we shared an interest in everything related to aviation and aeronautics, and this has been so, since we went to kindergarten.

The first problem that came up was to decide on what exactly we wanted to build. Anyone can buy a model helicopter set or glue together the wings of a model glider, but we agreed to make something completely different.

– An airship! –

There it was, the idea of something completely different. We would build a radio-controlled blimp, a combination of designing, calculating, constructing, and flying a quite special aircraft.

As soon as the idea was there, the enthusiasm and excitement joined in. Although we were forced to start from scratch with a project turning out to be almost pioneering work, we soon had our first successes and failures behind us and nothing could stop us any more. The blimp “Simon” would become reality.

Now, everything is done. When looking back, we must admit that designing was hard, the calculations consumed almost as much time as brain cells, the construction again almost as much glue and epoxy, but learning how to handle an airship actually floating in the unpredictable air, its currents and whirls has beaten everything there was before. Thus, with this report, we wish to give you, the reader, the most essential facts about blimps, the solutions to their most common problems and a few more complex ones. Take care of them, we had to find them all on our own!

Cyril Lutz & Maurice Rüegg
February 1998

Abstract

The following report is divided into two parts. In “Airship Design”, general aspects and considerations about airship-building combined with direct relations to this project, the blimp “Simon”, will be presented. Secondly, in “The Construction of ‘Simon’”, the progress of the ideas and choices concerning the many possibilities on how to construct an airship are shown and the way they were put into deed. Here, blimp science is not explained but applied in real, with an analysis of the result, the blimp “Simon”.

Nomenclature

a	½ Length of Ellipsoid	m
b	Radius of Ellipsoid / Cylinder	m
c _r	Index of Air Resistance	-
F _G	Weight	N
F _{Lift}	Static Lift	N
F _r	Air Resistance	N
g	Gravitational Constant	m•s ⁻²
l	Length of a Cylinder	m
L	Length of a Curve / Hullpart	m
p	Pressure	Pa
S	Surface	m ²
T ₀	Air Temperature	°C
T ₁	Lifting Gas Temperature	°C
v	Velocity	m•s ⁻¹
V	Volume	m ³
W	Width of a Hullpart	m
ρ	Density	kg•m ⁻³

Abbreviations

EoR	<u>E</u>llipsoid <u>o</u>f <u>R</u>evolution
GFG	<u>G</u>lass <u>F</u>ibers and <u>G</u>lue compound
H	Hydrogen
He	Helium
Li	Lithium
MC	<u>M</u>iddle <u>C</u>ylinder
VT	<u>V</u>ectored <u>T</u>hrust

Part I

Airship Design

1. Introduction

a) What is an Airship?

An airship is a type of lighter-than-air aircraft with propulsion and steering systems. It obtains its buoyancy from the presence of a lighter-than-air gas such as H, He, or hot air, based on Archimedes' Principles. The first airship was developed by the French; called a "ballon dirigeable", it could be steered and also be flown against the wind, which is not possible with a simple balloon.

Vehicles such as airships belong to the category of aerostats because of their ability to stand in the air. Airships and balloons are the two subcategories of aerostats. There are three types of airships: rigid, semirigid and nonrigid. Hot air airships can be counted as a part of the nonrigid category.

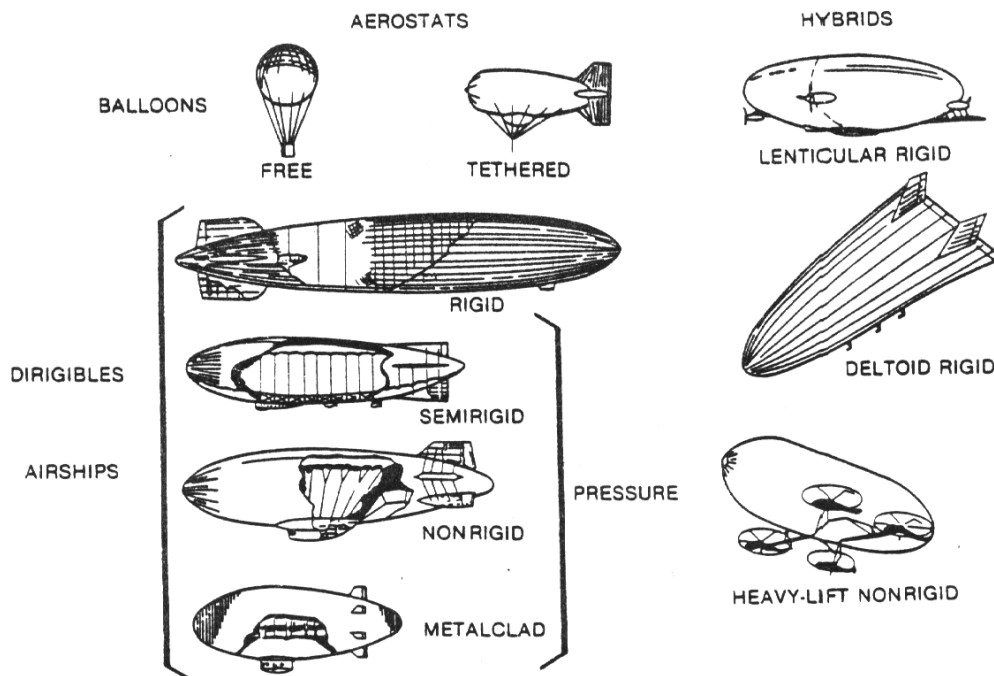

Figure 1. Types of lighter-than-air aircraft, with the two main categories of aerostats and hybrids.

b) What is "Simon"?

"Simon" is a research project with the purpose to build a large-scale model of an airworthy radio-controlled airship with minimal resources and a design never seen before. As a so-called blimp¹, it has no rigid internal structure and obtains the shape of its hull only by internal overpressure. The only solid parts are the gondola and the tail fins. The advantages of this nonrigid structure are obvious. Not only is the ship many times lighter than a comparable rigid airship, but also almost as resistant to weather conditions, if an adequate envelope material is chosen.

With a length of 4.8 m, “Simon’s” dimensions² are adapted to outdoor weather conditions. The smaller a blimp gets, the harder it is to control it in even small currents of air.

“Simon” is unique in many aspects:

- It is a “stand-alone”, completely independently developed project, since scientific literature on airship research does almost not exist.
- The design of its envelope combines the application of computer-aided calculation and a special technique of assembling the hull.
- The gondola has been designed and shaped by hand, the material used is a compound of glass fibers and glue (GFG), processed with no means of industrial machines.
- A special VT (vectored thrust) system with two independently controllable motors has been developed for steering the airship.
- A minimum of expenses has been realized to achieve the aims of the project.
- The airship may be de- and reassembled for transportation purposes in very few time. Deassembled, it takes up about a quarter of a cubic meter of space!

2. Buoyancy and Lift

a) The Lift Logo

Any vehicle operating in a medium may obtain lifting forces from three primary sources, as shown in Figure 2, the Lift Logo.

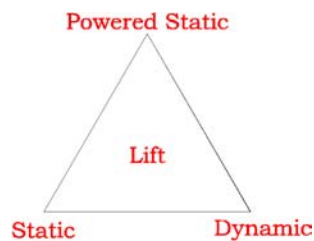

Figure 2. The Lift Logo.

The most economical of these forces from the production of lift point of view is undoubtedly the static lift wherein buoyant force is generated by the displacement of a portion of the supporting medium by the body. For a waterborne vehicle, this lift is embodied in the displacement ship, and for airborne vehicles, this is the balloon.

The inefficiency of the static lift vehicle comes when it is required to move through the surrounding medium. Due to the nature of displacement buoyancy, these vehicles tend to be very large and, as a result, they develop a great deal of dynamic drag when in motion. The dynamic effects of the motion can be used to an advantage, however, if the motion can be used to generate lift. By shaping the body, or a portion thereof, as a lift producing foil, a lifting force may be developed to support the weight of the body, provided sufficient forward speed is attained. In air this is the airplane, while in water this the hydrofoil craft.

A principle disadvantage of the dynamic lift vehicle is that it requires forward motion of some finite velocity to generate the lift. As a result, this vehicle can neither fly very slowly nor can it remain airborne at zero forward velocity (hover). If these attributes are required, one must provide some sort of internal powering for the static lift, such as a vertical jet exhaust, or a propeller with a vertical downflow. In air this is the helicopter or special aircraft, and on water (or in close proximity to the earth) this is the air cushion vehicle or hover craft.

¹ Blimp is a British slang expression of unknown origin.

² For more data, see Appendix A: Technical Information of “Simon”.

Having defined these primary sources of lifting force, one might observe that it is possible to use two of these sources, or even all three, in combination. By doing so, one moves from the pure lifting force source, for example static lift, to a hybrid source, such as a partial static lift and a partial dynamic lift. This is exactly the technique used with “Simon”. Its envelope produces static lift, while the two motors provide powered static lift and dynamic lift when the hull is positioned in a way shown in Figure 3.

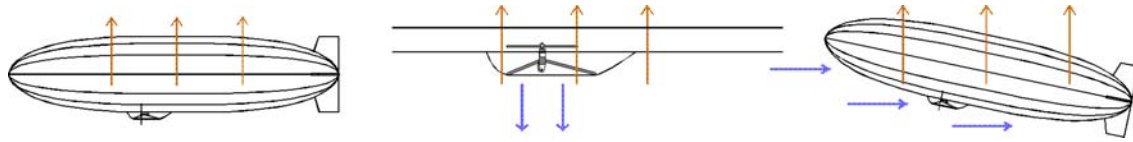

Figure 3. Static, Powered Static, and Dynamic Lift.

b) Static Lift of an Airship

Obviously, when looking at an airship, the amount of static lift is the most important. Because it plays the decisive role on whether an airship will float or not, it will be looked at closer in the following.

The principal tenet of static lift is that a body displaces a volume of the surrounding medium whose weight is equal to or greater than the total weight of the immersed body. If the weight is equal, the body is said to have neutral buoyancy, while if the weight of the body is less than that of the displaced air, the body has a positive buoyancy. The lift of He in air is obtained as following

$$F_{Lift} = (\rho_{air} - \rho_{He}) g V \quad (1)$$

If one were to ignore the weight of the required enclosure (the envelope) and consider only the static lift of various gases, calculated by the above formula, one would find a relationship of specific lift as it is shown in Appendix C, Table 1.

The data of Table 1 is based on 100 % pure gas at standard sea level conditions and at the same temperature as the air that is displaced. It can be seen from Table 1 that the greatest static lift is to be obtained from H with He a close second. It has to be noted that although the weight of a given volume of He is approximately twice that of an equal volume of H, inasmuch as the lift is the difference between the weight of the gas and the weight of air, the lifting capacity of H is but about eight percent greater than that of He³.

When considering the high degree of flammability of H, one might ponder why that gas is even considered as a static lift source. The answer lies in the economics of its procurement. Wherein He must be mined or extracted from minute quantities in the atmosphere, H can be obtained inexpensively from the electrolysis of water.

Due to the natural impurities that are present in He as it is recovered from the earth, and due to the cost of extensive refining, commercial He is seldom available at greater than 98 percent purity. This means that the lifting force of He depends on its purity and is never 100 percent.

³ For exact numbers, see Appendix C, Table 1.

c) Temperature and Pressure

Very important for the correct use of aerostatic systems is the knowledge of the weather and its tendencies. The most important influences emerge through air pressure and temperature changes.

As the airship ascends, the lifting gas expands due to the reduction of the ambient air pressure. This pressure can be expressed as an index, the standard atmosphere (ISA), which indicates the air density for different altitudes above sea level⁴. To prevent overpressure inside the airship hull as the airship rises, ballonets and valves⁵ are used to level out the differences in pressure. With valves, the pressure may be regulated by radio signals. Ballonets are small balloons inside the hull of an airship, filled with air and, as pressure rises, losing air automatically. There is some altitude at which, with the ballonets completely empty, it is just possible to return to the ground with the ballonets filled to capacity. This altitude is called Pressure Height. Flight above Pressure Height will result in the ballonets becoming completely filled prior to the airship reaching the ground on its descent and then some other measures must be taken to maintain the shape and pressure of the envelope. The most common measure is the addition of air to the lifting gas using the previously mentioned safety valve.

Unless the pressure airship is considerably above the Pressure Height, a decrease in altitude or an increase in barometric pressure will have little or no effect on the static lift inasmuch as the lifting gas will contract and the airship will no longer be at Pressure Height.

Because of local heating, usually from the sun on the envelope, it is possible for the lifting gas to be at a different temperature than the surrounding air. If the sun heats the lifting gas so that it is at a higher temperature than the surrounding air, a condition called “Superheat”, the same weight of lifting gas displaces a larger volume of air, and therefore a larger weight of air. This produces an increase in static lift.

For one hundred percent pure He at standard sea level conditions, below Pressure Height, a 3°C “Superheat” will increase the static lift by about 2 percent.

Inasmuch as the specific density of the gas is inversely proportional to the ratio of absolute temperatures, the percentage increase in static lift due to a temperature increase may be found from the relationship

$$F_{Lift} = 100 \frac{T_1}{T_0} - 100 \quad (2)$$

Because of these large influences of the sun, winds and air pressure on aerostatic systems, it is recommended to let an airship fly at sunrise or sunset, in order to avoid strong currents.⁶

⁴ See Appendix C, Table 3.

⁵ Techniques “Simon” does not take advantage of. See also part II, 4. c) Improvements.

⁶ Additionally, the load capacity is larger, because of lower outside temperatures.

3. The Envelope

a) Dimensions – The Look of a Zeppelin

The envelope or hull is the main part of an airship because, as the wings of a plane, the envelope decides if an airship is going to fly. Most radio-controlled airships are nonrigid and their envelope is usually in the shape of a cigar that is kept in form by internal overpressure. Rigid models often encounter serious overweight problems because of an adverse weight to volume ratio. The most difficult task is to choose a material which makes the envelope light, tough, and most important of all, heliumtight. The envelope is often the factor that keeps people from building model airships because it is something that cannot be found in other aircraft models.

It is very important to give an airship its special design. Some people might find it nostalgic or even a waste of time to design an airship in its unique form. This is simply not true. The previously mentioned cigar-shaped hull gives an airship stability, low air resistance and a maximum amount of lift. Tried and tested, very reliable and effective designs are the Goodyear blimp design [Airship Design and Operation], Prill's semirigid design [Prill], or, of course, Zeppelin's own, more than 100 slightly variable designs⁷. For "Simon", another aspect was the feasibility of the hull construction with limited means⁸ and minimum expense. Along with this considerations came the demands "Simon" had to fulfill. It had to be the smallest blimp possible for outside operation. Thus, the design of an EoR combined with a MC was chosen, as described in part II of this report, after the simple formula for the volume of an EoR (3) and a cylinder (4)

$$V = \frac{4}{3} \pi a b^2 \quad (3)$$

$$V = b^2 \pi l \quad (4)$$

b) Volume, Lifting Force, and Weight

In chapter 2. b) Static Lift of an Airship, it becomes clear that the lifting force of an airship is directly related to the volume of its hull by equation (1). The weight, however, determines both of these values. The airship needs a lifting force at least as big as the overall weight of its components to be able to float in the air. Since temperature changes and pressure variations influence the ideal lifting force⁹, it becomes necessary to calculate an ideal lifting force and volume big enough to overcome these influences. More is better than less. Also, it is often very difficult to calculate the overall weight of an airship in advance.

It is recommended to actually construct as many of an airship's parts as possible, i. e. the gondola, the propulsion, the fins, before deciding on the exact volume of its hull.

⁷ See Appendix D

⁸ Normally, the hull is welded together, which was not an option for this project.

⁹ The ideal lifting force refers to a temperature of 0°C and a pressure of 1.013 x 10⁵ Pa.

For “Simon”, an ideal lifting force about 10% bigger than its weight was calculated. This left enough elbowroom for weather moods and eventual changes or improvements and additions to the blimp.

4. The Gondola

a) Functions

In general, the gondola of a radio-controlled airship contains the receiver and batteries and has the motors attached to its outside or back. The easiest solution is probably to have one motor aft, but it is definitely more effective in terms of steering to have two motors, one on each side like on most of today’s blimps. The alternative to gondola mounted motors is to have them in separate gondolas on the sides of the ship or underneath it, as it has been done with the historic Zeppelins. Having them at a distance from the other equipment helps to distribute the weight load and avoids interference of their magnetic fields with the receiver. Also, the danger of damaging the hull is smaller. To completely avoid this danger, impeller motors may be used¹⁰. Furthermore, if the motors can be operated independently, a wide separation increases the maneuverability of the airship.

b) Form and Dimensions

A gondola needs to combine two things. First, the weight of it has to be as small as possible and the stability very high, to bring up the question of the material to be used. Secondly, it has to be large enough to enclose the batteries and electronics. As a third aspect, an aerodynamic form might be considered. Because the exact center of gravity of an entire blimp can hardly be calculated, it is a good idea to leave space inside to move the batteries¹¹ and balance the blimp as a whole.

Glassfibers and epoxy, GFG, is the preferred material in such situations because of their toughness and lightness. Processing may prove to be hard, since GFG is normally formed through overpressure or an applied vacuum [Nicholls], but if not done so, the outcome simply lacks smoothness.

5. Flight Dynamics

a) Steering

There are many possibilities to control and steer a floating airship in the air. For “Simon” a most sensitive and weather conditions independent solution was developed. “Simon” has

¹⁰ For the advantages and disadvantages see also part I, 6. b) Motorization.

¹¹ The batteries of a model blimp make for almost a third of its entire weight.

two motors, on each side, connected through a movable axle, that can tilt up and down. This feature is called VT.

VT allows for very exact vertical steering of an airship. It may replace the less effective rudders, which tend to react slowly because of the only low speeds of an airship.

VT produces powered static lift as shown in Figure 3 above and may play an important role in fine-calibrating the float of an airship. It makes it possible for an airship to descend without the use of a valve or other means of letting off He.

Since the two motors of “Simon” can be operated independently forth and back and are separated by over 1 m from each other, they provide a great horizontal maneuverability. One motor thrusts forwards, the other backwards, as shown in Figure 4. Backward thrust is a little smaller than forward thrust because of the special shape of the propellers.

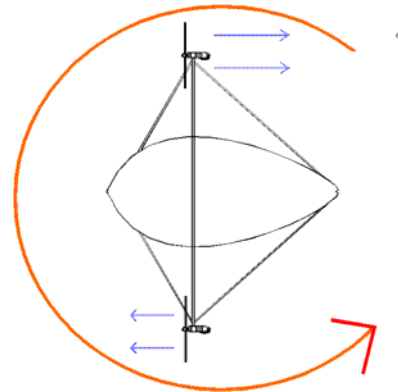

Figure 4. Horizontal steering.

A special feature important for any airship is the possibility to operate the motors forth and back, to produce thrust in both directions. In combination with VT, this enables the airship to ascend, descend, and make sharp turns in both directions.

b) Friction and Air Resistance

In order to choose the right motorization for an airship, friction and air resistance may not be neglected. Friction depends on the material used. For “Simon” a mylar¹² foil is used for the hull, which is fragile but tough and insulating. With mylar, friction is very small, not relevant. It’s different with air resistance. An aircraft always produces resistance, drag in the air, depending on its size and velocity after the equation

$$F_r = \frac{1}{2} c_r \rho v^2 S \quad (5)$$

The index of air resistance c_r may be found through wind channel tests for different bodies. The index of an EoR lays in between 0.05 and 0.5, depending on the length to width ratio of the body.

In “Simon’s” case, the calculation of air resistance is important because it determines the power of the motors to choose. All calculations conducted ignored possible winds and other atmospheric influences on air resistance since the calculation was only theoretically possible with a c_r estimated to be 0.35¹³.

¹² Mylar is a polyurethane sold as survival blankets in outdoor stores.

¹³ See part II, 5. b) Air Resistance – An Approximation.

c) Stabilization

Tail surfaces are needed to stabilize an airship. At the University of Toronto, extensive studies showed the influences of stabilizers for an airship, and the conclusion drawn recommended to always use fins with an airship [Lagrange].

Tail surfaces and rudders need to be designed so that they allow effective control of the directions of the airship. Because of “Simon’s” VT and independently controlled motors, rudders are not necessary to further control him. Also, they are only of limited practical use because of small speeds as mentioned earlier in this report. Stabilizers are used and designed in a way to stabilize, but not to overstabilize. Overstabilization means a limitation of the airship’s agility through too large fins. Again, with too small fins, the ship often progresses in a wave-like motion.

Tail surfaces for airships are built in the same way as those for radio-controlled planes, just lighter and especially with more surface. Light balsa wood or Styrofoam structures covered with Monokote are recommended. That is exactly how “Simon’s” stabilizers are built. Its four fins have an adequate height of 0.55 m each, and a length of 0.40 m.

6. Electronics and Motorization

a) Electronics

Inside the gondola, all the electronics needed to properly control an airship are arranged. They may include a servo to tilt the motors, accumulators, speed controllers, a receiver for the radio-control system and batteries supplying it with power.

Usually, accumulators are bought connected to one another in series¹⁴. It is possible to use other accumulators than those for model planes and cars; Li-accumulators (used in notebook computers) are no more expensive and considerably lighter. Whatever is chosen, it has to be light!

b) Motorization

There is always the option of using either combustion engines or electric motors for model aircraft. The advantage of electric power is that it allows for very precise throttling combined with electronic speed controllers. Even though an electric system is generally heavier than a combustion engine, the added benefit of reversibility will drastically improve low speed maneuverability. In addition, an electric system keeps the same weight and does not affect buoyancy, unlike an engine that burns gas and makes an airship lighter during flight. Usually, large propellers with low rpm¹⁵ (possibly through a reduction gear) are more efficient than small, fast turning propellers.

Possibly, impeller propellers may be used. Because of their turbine-like making, they provide excellent protection of the hull from eventual propeller hits. Also, they are easy to glue to a tilting axle for VT. Normal electric motors need to be welded to the axle. Their disadvantage is fewer thrust compared to normal propellers.

¹⁴ For an explanation, see <http://ourworld.compuserve.com/homepages/mo78>

“Simon” uses normal 0.115 m, 6–9 propellers for thrust, combined with two 110 W motors. They proved to be dependable and efficient.

7. Etceteras

a) Flight Certification

Fundamentally, radio-controlled balloons and airships are subject to the same restrictions as other radio-controlled flying models.

There is the question of the use of H as the lifting gas for balloons and airships instead of the much more expensive He. Common belief is that it is forbidden. The rumor is wrong; a restriction only exists for commercial employment of manned airships with H. Still, H is usually much harder to obtain because of its dangers.

There are no exact building regulations and determinations of “small and light” aerostats. When planning a craft of more than 20 kg total weight, sketches and calculations are to be shown, however, to the authorities for permission.

b) Meteorology and Atmospheric Effects

As mentioned in chapter 2 c) Temperature and Pressure, the lift of the different gases changes through many different meteorological influences, and a small airship is hard to control in even weak currents. Additionally, the danger of losing the airship due to an upward current is always high for an inexperienced airship pilot. If possible, the tryout and “inaugural flight” of a small airship should be made indoors, or if not possible during the morning of a calm summer day. The authors are talking from experience...

¹⁵ **Rounds per minute.**

Part II

The Construction of “Simon”

1. First Steps

a) Hull Shape

The most important aspect of the blimp “Simon” was its overall design and the dimensions of its envelope. Because the actual size could not be evaluated before the weight of the structure was known, a first design only included the form and ratio of the hull and not its final dimensions.

Two aspects were important when designing the front or tail piece of the blimp. There was the look of a Zeppelin, an aerodynamically formed nose and a tail possibly pointed or round. Also, there was the volume to surface ratio affecting air resistance, wind influences and most important, cost. “Simon” took a special approach to a design of an EoR, giving it the look of a blimp. Different length to width ratios were drawn and their volume graphs¹⁶ had to be calculated to be able to compare the advantages of each design as shown in Figure 1.

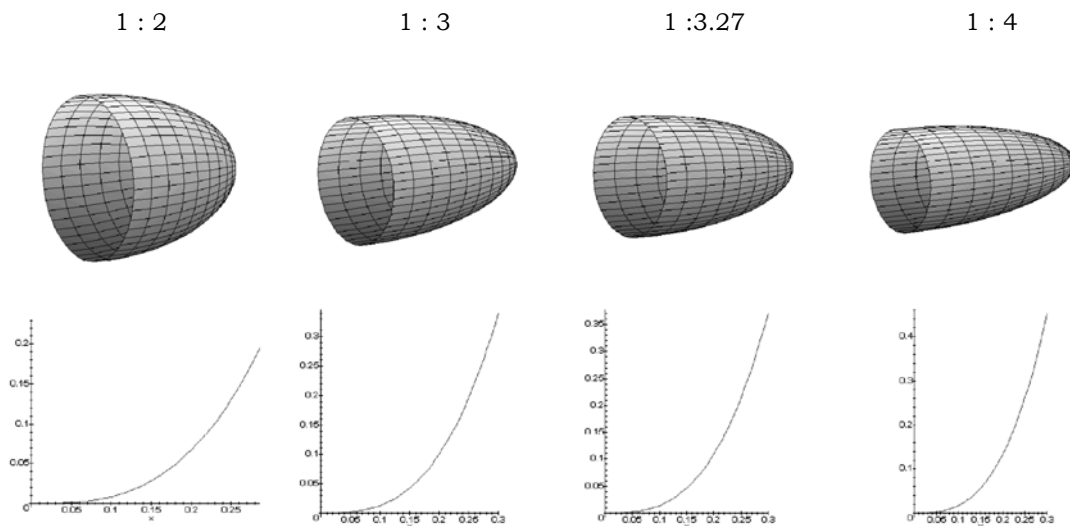

Figure 1. Various ratios of ellipsoids with their volume graphs.

A ratio of 1 : 3.27 was finally chosen as shown above. The advantages are a large volume even for small radii and thus a large lifting force and low air resistance. At the same time, the ratio “looked good”.

In the same way, a MC was fitted into the system. Its length was determined to be two thirds of the length of half an ellipsoid. The final shape ratio of “Simon” is shown in Figure 2.

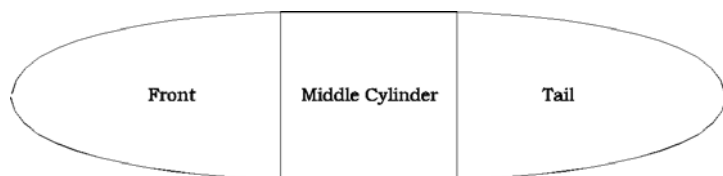

Figure 2. The final shape.

¹⁶ Because only ratios were calculated, volumes had to be expressed as variables.

b) A Gondola

The gondola design proved to be quite hard. Since computer models were not satisfying, the form of the gondola was developed by hand, simply by drawing various sketches. Figure 3 shows the final aerodynamic shape. Already included in Figure 3 are the actual size of the gondola and the point where the tilting axle would be. The size was chosen because of considerations including the size of the accumulators, a width supporting the tilting axle and the weight of the motors and propellers, and space for the electronics. The axle would be at the largest width of the gondola. The material to be used is called GFG, light and tough.

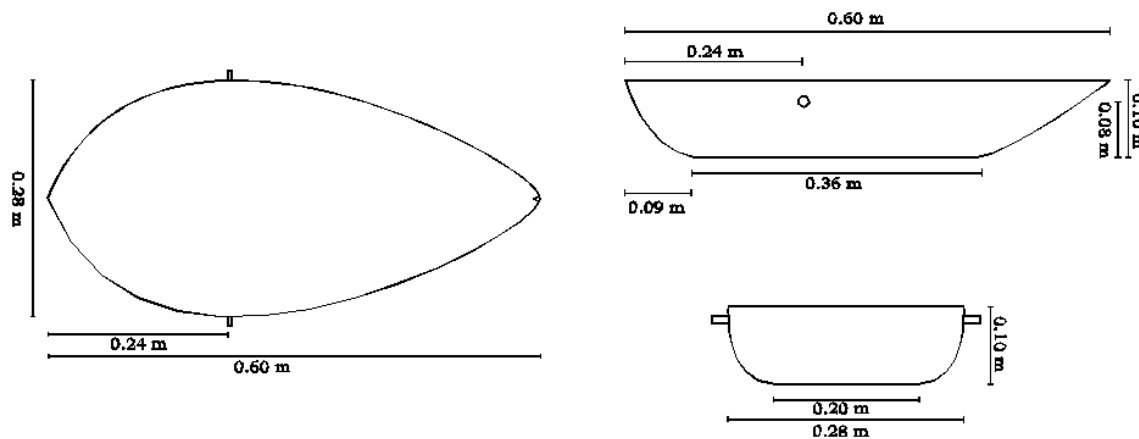

Figure 3. The form of the gondola from above, the side, and the front.

c) Dimensions

It finally got time to set “Simon’s” actual size. Thus, the electronics, a servo, two motors, two speed controllers, a receiver, and 16 accumulators were bought and weighted. Mylar foil was also weighted, together with the balsa wood needed for the stabilizers.

It can be said, that the dimensions of an airship depend on the power output of its motors, since the motors and accumulators make up for the largest part of its weight. The more power the motors produce and the more accumulators are needed, the bigger the airship gets.

The volume to radius ratio, and thus also the lifting force for a given radius of “Simon” had previously been evaluated as shown in Figure 1. Because motor power output – and the weight of the motors – also depended on the size and volume of an airship, the following relation between F_G and F_{Lift} was drawn in Figure 4. Since “Simon” was meant to be an outdoor blimp, fighting against wind and turbulences, it had to be motorized sufficiently, meaning a quite large motor weight. Not expressed in the graph are the influences of inertia and other more complicated aspects, since the graph itself is only an approximation.

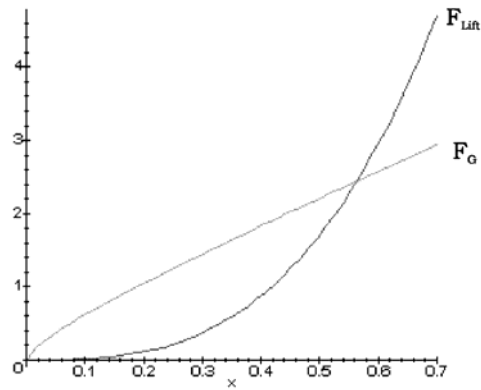

Figure 4. Lift weight relation. The x-axis shows the radius of the ellipsoid.

From the graph in Figure 4, the minimum dimensions of “Simon” could be determined. They lay around a radius of 0.5 m and thus an overall length of 4.3 m. As previously mentioned in part I, 110 percent of these values were used for “Simon” to take precautions against any eventualities. “Simon” now looked as in Figure 5.

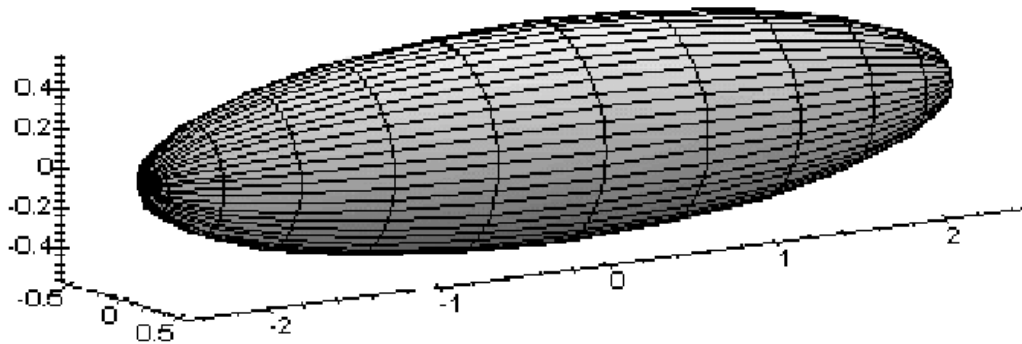

Figure 5. “Simon”: 4.8 m • 1.1 m • 1.1 m.

2. Calculations¹⁷ and Model Construction

a) Hull Values

It is always best to find out the main data of an airship, to see where possible problems might come up. Is F_{Lift} large enough? How large is the surface of the blimp? etc.

The exact volume of “Simon” had been calculated by formula (3) and (4) already mentioned in part I. The origin of (3) derives from the equation of an ellipsoid

¹⁷ Some of the more complicated problems were solved with the aid of the mathematical computer program Maple V Release 4.

$$\frac{x^2}{a^2} + \frac{y^2}{b^2} = 1 \quad (6)$$

$$f(x) = \sqrt{b^2 - \frac{b^2 x^2}{a^2}} \quad (7)$$

The formula for any body of revolution and thus also for “Simon’s” EoR is expressed through

$$V = \int_{-a}^a \pi f(x)^2 dx \quad (8)$$

When substituting (7) for f(x) one gets the final formula for an EoR

$$V = \int_{-a}^a \pi \left(b^2 - \frac{b^2 x^2}{a^2} \right) dx \quad (9) \quad V = \frac{4}{3} b^2 a \pi \quad (3)$$

When formulas (3) and (4) are evaluated, the volume of the ellipsoid and cylinder equal to 3.42 m³.

F_{Lift} of 100% pure He (ideal gas) in air at 0°C and 1.013 x 10⁵ Pa is equal to 10.9 N per cubic meter. Using equation (1), a F_{Lift} of 37.4 N results. This value may change through pressure and temperature influence, expressed in equation (10)

$$\frac{p_1 V_1}{T_1} = \frac{p_2 V_2}{T_2} \quad (10)$$

Also, it is important to know the surface of the envelope to estimate the weight and price of the envelope material needed. It is given by the equation for the surface of revolution of a body, derived from the length L of a curve

$$L = \int_{-a}^a \sqrt{1 + \left(\frac{\partial}{\partial x} f(x) \right)^2} dx \quad (11) \quad S = \int_{-a}^a 2 \pi f(x) \sqrt{1 + \left(\frac{\partial}{\partial x} f(x) \right)^2} dx \quad (12)$$

where, again f(x) is substituted by equation (7). Also, the equation for the surface of “Simon’s” MC must be considered. It is

$$S = 2 \pi b l \quad (13)$$

The final surface is expressed through

$$S = 2 l \pi b + \int_{-a}^a 2 \pi \sqrt{b^2 - \frac{b^2 x^2}{a^2}} \sqrt{1 + \frac{b^4 x^2}{\left(b^2 - \frac{b^2 x^2}{a^2}\right)^2 a^4}} dx \quad (14)$$

“Simon’s” surface equals to 14.3 m².

b) Calculating Hullparts

How may one build a three-dimensional blimp from plane mylar foil? This was a central question when building the blimp “Simon”. Obviously, it could not be done with one piece, but needed the more, the rounder the structure had to be. Too many pieces, however, would have made the construction last forever. Thus, it was decided that “Simon” would be made of 26 pieces, 12 for the front, 12 for the tail and 2 for the MC. Each of them had an additional glue fold.

The hullparts where obtained by dividing the circumference of the ellipsoid by 12 at every point x of the x-axis as shown in Figure 6

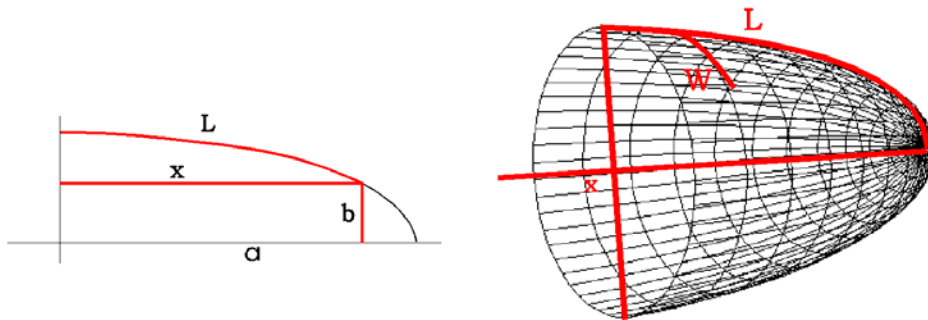

Figure 6. How to calculate the hullparts in 2D and 3D.

The length L and width W of the plane and twodimensional hullpart could be calculated from the x values of the threedimensional elliptical form with the help of equations (7) and (11) resulting in the following equations (15) and (16)

$$L = \int_0^x \sqrt{1 + \left(\frac{\partial}{\partial x} \sqrt{b^2 - \frac{b^2 x^2}{a^2}}\right)^2} dx \quad (15)$$

$$W = \frac{1}{6} \pi \sqrt{b^2 - \frac{b^2 x^2}{a^2}} \quad (16)$$

Also, the form of the MC was calculated and the final result looked like Figure 7.

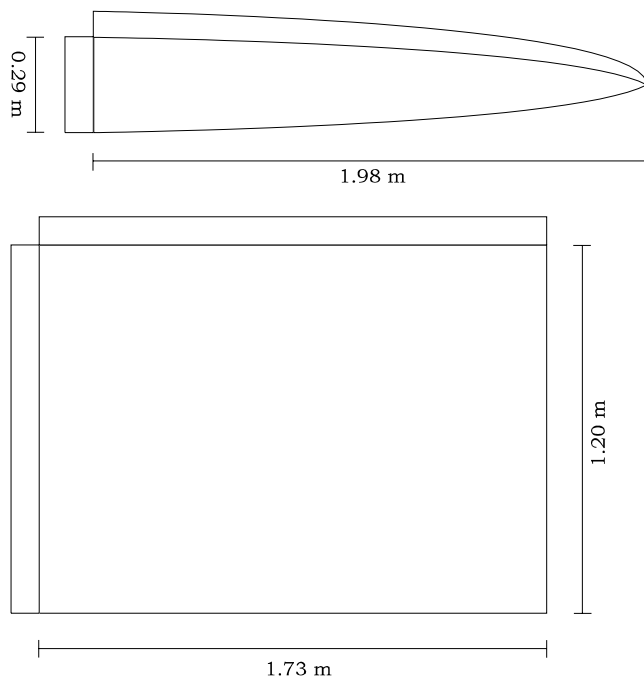

Figure 7. Final shapes of the hullparts¹⁸.

To be able to draw and afterwards actually cut out “Simon’s” hullparts, the L and W values for a given point x needed to be evaluated as listed in Appendix B.

c) First Models

To control the correctness of the hullpart calculations and see the gondola in 3D, both, the hull and the gondola, were built as a model first. From paper, a hull was put together in the actual design of “Simon” in a scale of 1:5, and from a polystyrene cylinder, a gondola was cut out true to scale. It could afterwards be used as a positive form of the real gondola¹⁹.

A model shows the dimensions in the room. It also helps doublechecking the theoretical work.

3. Construction of the Main Parts

a) A Tilting Axle

¹⁸ The MC pieces could not have been chosen any larger because the mylar foil was only available in small pieces.

¹⁹ For illustrations on the process and the models, see <http://ourworld.compuserve.com/home-pages/mo78> or “The Design and Construction of the Radio Controlled Airship ‘Simon’”, “A Picture History”.

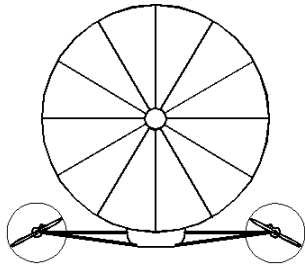

Figure 8. The front.

The application of VT, as already described in part I made it necessary to construct a tilting axle. For “Simon”, a simple construction as in Figure 9 was chosen. VT allows for two different options. Either only the propellers or both the motors and propellers are mounted at the tips of the axle. To mount only the propellers rises the problem of connecting the motors with the propellers through the axle. To mount the motors and the propellers causes a stability problem: The axle has to support the weight of the motors and the propellers. It was decided that

“Simon” would support a system with the motors and propellers mounted at the tips of the axle; an aluminum pipe (diameter: 8 mm) was used to overcome stability problems. The axle and motors were mounted as shown in Figure 8, “Simon’s” front.

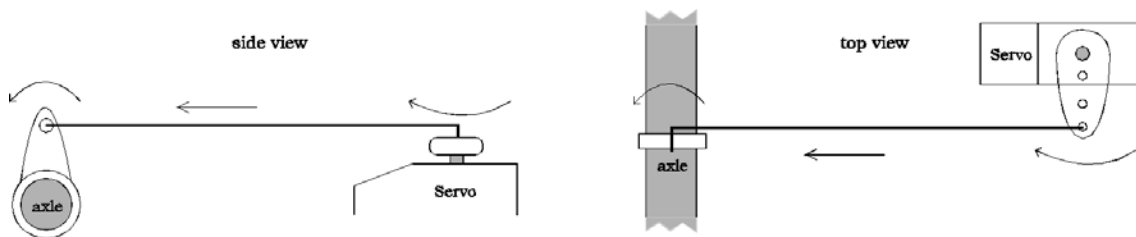

Figure 9. The tilting axle, controlled by a servo.

b) Construction of the Gondola and the Hull

Since a polystyrene model of the gondola was already made, it was used further to construct the gondola. From the polystyrene shape, a negative form of plaster was cast. After a week the plaster was dry and a layer of wax and one of GFG were laid inside the negative form. The wax kept the plaster from sticking to the GFG. Figure 10 illustrates the process. Once the shape of the gondola was finished, holes for the tilting axle were drilled and supporting aluminum braces were glued to the axle and the gondola. The axle was additionally supported by four ball bearings.

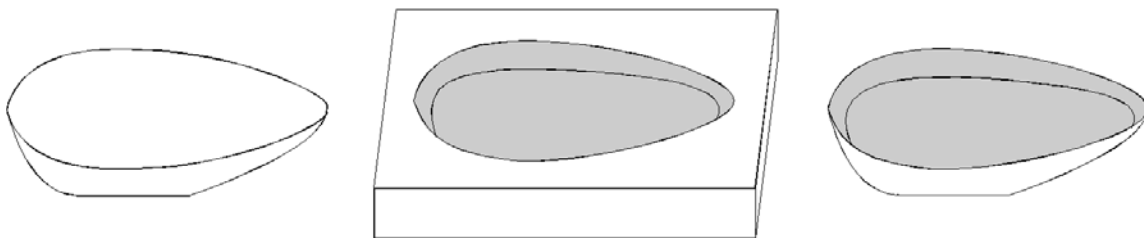

Figure 10. Polystyrene, Plaster, GFG.

Next, the hull had to be put together. Conducting various tests, it was found that contact glue was the ideal adhesive for making the hull heliumtight, since welding was not an option for a polyurethane like mylar. Because the outermost front and tail parts were extremely difficult to glue “threedimensionally”, a polystyrene body to fit the front and tail of the airship was sanded. It could be used as a 3D surface for gluing. It took 30 to 40 hours of gluing and four tubes of glue to put the envelope together. A valve and two pieces of wood were then placed inside the hull. The valve, with a diameter of 0.01 m, would be used to

inflate the blimp, the two pieces of wood to mount the gondola to the hull. The gondola would be coupled to the envelope through four mounting points, shown in Figure 11. Four screws from inside the envelope went through the pieces of wood and attached the gondola to the rest of the airship with wing nuts.

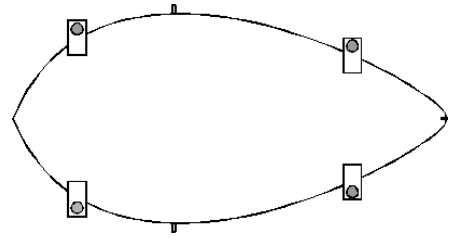

Figure 11. The mounting points.

c) The Electronics

Inside the gondola, the electronics needed to properly control the airship were arranged as shown in Figure 12. They included a servo to tilt the motors, sixteen 1.2 V accumulators, two speed controllers, the receiver of the radio-control system and four batteries supplying it with power. Eight accumulators made up an Accu Pack, connected to each other in series. The receiver controlled the servo and the two motors with their speed controllers. This way, the motors made up two independent parallel circuits.

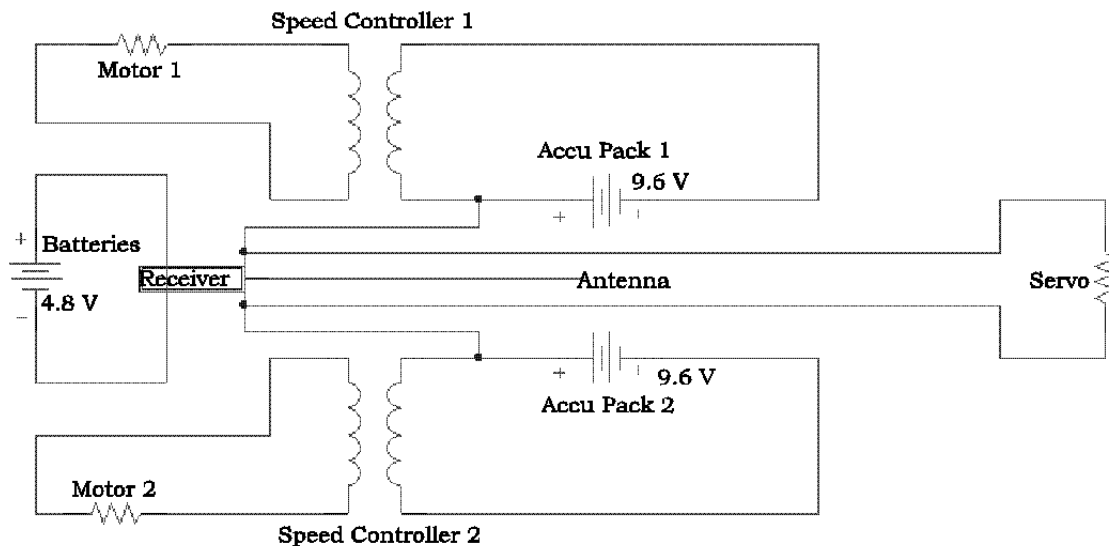

Figure 12. "Simon's" Heart

d) The Fins

At last, tail surfaces were designed. “Simon’s” four fins became huge with a height of 0.55 m each, and a length of 0.40 m, but compared to the envelope, they seemed extremely small. Figure 13 shows their dimensions.

Made of Monokote and light balsa wood, the fins are extremely light. Still, they needed to be considered when evaluating the center of gravity of the blimp. The exact center of gravity could only be located empirically, in “Simon’s” case with a large scale.

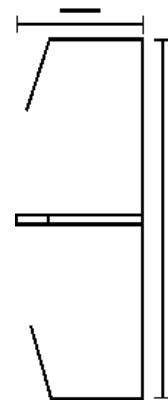

Figure 13. The fins.

4. First Experiences and Improvements

a) Flight Preparations

When all parts were built, they needed to be put together. After connecting all the electronics inside the gondola and turning the power on, the gondola could be mounted. Then, the He was filled in through the valve until “Simon” started to float. The fins were attached to the tail by tape. Because of the extra weight of the fins, more He was filled in. When “Simon” floated again, the He was substituted by air, filling the envelope all the way, giving it its final shape and producing a slight overpressure.

b) Flying a Blimp

It is no secret now: “Simon” got too small. Even with little wind, the airship was shaken by ever little airstream. The problem was not caused by undermotorization or too small fins. With absolutely no wind “Simon” obtained speeds of up to $5 \text{ m}\cdot\text{s}^{-1}$ and flew completely steady. Thus, the small airship “Simon” involuntarily got only a “calm-weather-blimp”. One simple measure helped a little to avoid unpleasant winds: flying at little altitudes!

c) Improvements

After the first practical experiences, many new and sometimes demanding problems arose. The valve was a little small: with a valve of a larger diameter, it would not take as long to inflate the blimp. Also, a safety valve would be preferable. This means some sort of a radio-controlled system to control the opening of the valve, or even an additional valve. There were many possibilities to solve the problem, but none of them was easily applicable. There would be the option of an electromagnetically controlled valve, a coil with an iron core and an applicable current. A one way version of a safety valve would be a thin membrane to be destroyed by a movable and sharp tool such as a needle. Third, there would be the mechanical valve, controlled by a servo. For “Simon” none of the above has been used yet, but the construction and use of a mechanic valve is heavily discussed at this very moment.

The motors also proved to be difficult to handle. For strong currents, they were not powerful enough, for calm weather, they were more than sufficient. Also, during the course of various flights, it was found that the motors heated up very fast because of a large current flow²⁰. It even occurred once that one of the motors melted out of its fixture. Thus, the use of other, less resistive motors turning at a lower frequency is discussed at the moment. The fixture of the motors has already been reinforced by ring clamps. Also the supporting aluminum braces of the axles have been reinforced. Previously, they got damaged during hard landings.

The envelope problem: In the beginning, the hull was amazingly very heliumtight²¹. But after a few crash-landings and many transportations of the blimp, it started to leak. The weak points are the vertical glue folds between the ellipsoid and the cylinder. However, the hull itself got damaged, as well, and many little holes, invisible for the eye, grew larger. Now test are being conducted with lacquers as Silicon to seal those holes.

5. Completion

a) Motor Thrust – An Experiment

How powerful are the motors, with the given propellers? The motors currently used are two Robbe Power Plus 410/12 with two 9–6 propellers. To experimentally determine the thrust of one of them, the mechanism as in Figure 14 was built.

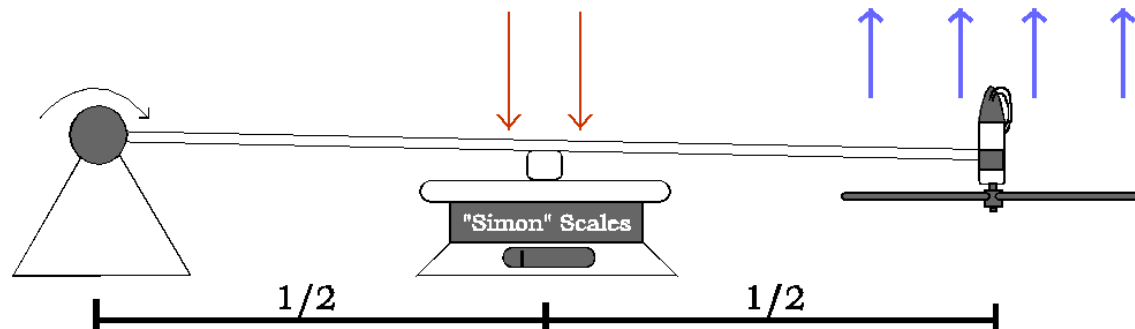

Figure 14. A scale to measure thrust.

Because of the mechanism, the shown thrust on the scale needed to be divided in half. A thrust of 3.3 N per motor was determined.

b) Air Resistance – An Approximation

Since thrust was known, it became interesting to determine air resistance. The difficult part was not the calculation, as already discussed in part I, equation (5) but the approximation of the index of air resistance c_r , since no wind tunnel facility was available. For a perfect sphere, c_r is 0.47, for a streamlined body 0.05. Also, equation (5) is only valid

²⁰ Currents measured during tests were up to 10 A.

²¹ He is the second smallest atom and after H and the smallest natural molecule ($H_2 > He$).

for turbulent streams. For the blimp “Simon”, turbulent streams were guessed to appear from a speed of $2 \text{ m}\cdot\text{s}^{-1}$ up. Thus, equation (5) could be written as following

$$F_r = \frac{1}{2} c_r \rho v^2 \pi b^2 \quad (17) \quad \text{for } 2 < v \quad \text{and} \quad S = \pi b^2 \quad (18)$$

ρ is the density of air, in this case $1.293 \text{ kg}\cdot\text{m}^{-3}$. For c_r an approximation of 0.35 was chosen, in the middle of the values of a sphere and a streamlined body, a little closer to a sphere. The graph in Figure 15 shows the relationship between speed (x) and air resistance (y). It may be seen that “Simon” has a maximum speed of $5.54 \text{ m}\cdot\text{s}^{-1}$. Beyond this value, motor thrust of 6.6 N is lower than air resistance.

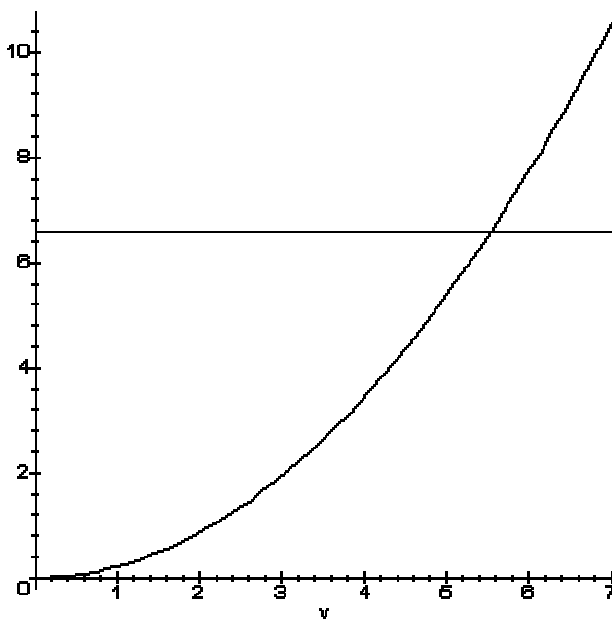

Figure 15. Air Resistance.

c) Helium Recycling

He is very expensive. Why not recycle it then? The problem is: To get the He out of the blimp envelope, a vacuum pump is needed. Cheap solutions for a vacuum pump are refrigerator compressors or pumps used to inflate rubber dinghies. Their capacities are very low, though and it takes a while to fully deflate a huge blimp envelope, even with a big pump. However, the main problem is storage. A heliumtight receptacle, possibly under overpressure has not been found yet. Maybe it will in the future of the blimp “Simon”...

Appendices

Appendix A: Technical Information of “Simon”

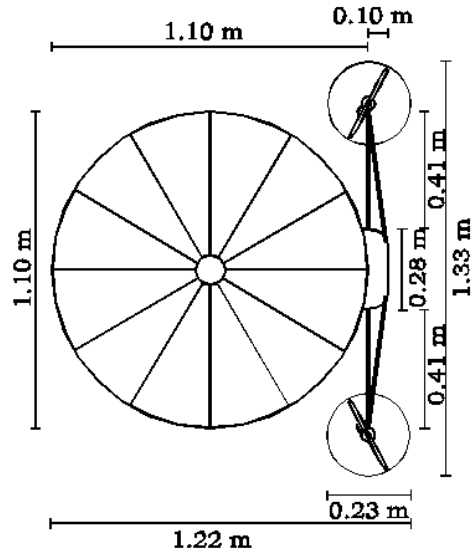
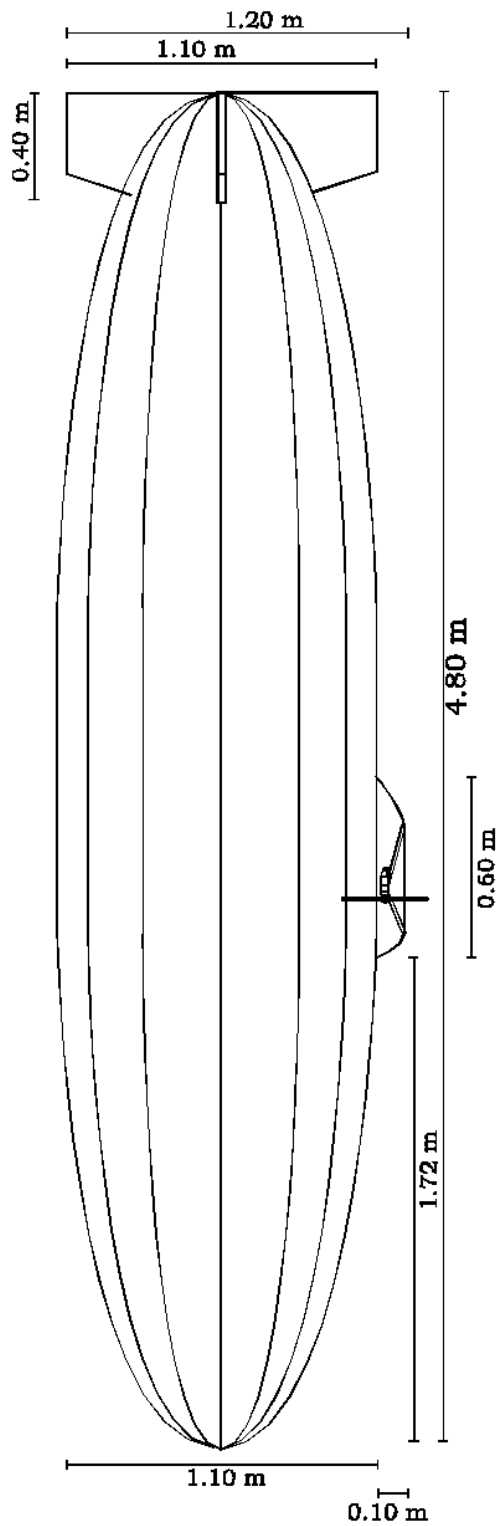

Maximum Length	4.80 m
Maximum Diameter	1.10 m
Volume	3.42 m ³
Surface	14.28 m ²
Mass	3.2 kg
Envelope Material	Mylar Foil (Polyurethane)
Motorization	2 Robbe Power Plus 410/12
Maximum Speed	ca. 6 m·s ⁻¹
Motor Power	2•110 W
Motor Thrust	2•3.3 N
Air Resistance at 5m·s ⁻¹	5.4 N
Lift with pure He at 1.103Ee Pa and 0°C	37.4 N
Vector Thrust Angle	-80° to 80°

Appendix B: Hullpart Data

x	L	W
0	0	0.1439896633
0.03	0.03000012969	0.1439696634
0.06	0.06000103806	0.1439096468
0.09	0.09000350630	0.1438095636
0.12	0.1200083207	0.1436693300
0.15	0.1500162753	0.1434888282
0.18	0.1800281745	0.1432679060
0.21	0.21004488358	0.1430063763
0.24	0.2400670927	0.1427040156
0.27	0.2700957976	0.1423605638
0.30	0.3001318251	0.1419757226
0.33	0.3301760753	0.1415491547
0.36	0.3602294776	0.1410804813
0.39	0.3902929939	0.1405692814
0.42	0.4203676236	0.1400150892
0.45	0.4504544075	0.1394173920
0.48	0.4805544331	0.1387756276
0.51	0.5106688397	0.1380891817
0.54	0.5407988247	0.1373573844
0.57	0.5709456499	0.1365795067
0.60	0.6011106490	0.1357547565
0.63	0.6312952355	0.1348822739
0.66	0.6615009123	0.1339611263
0.69	0.6917292816	0.1329903025
0.72	0.7219820567	0.1319687062
0.75	0.7522610749	0.1308951487
0.78	0.7825683127	0.1297683402
0.81	0.8129059031	0.1285868809
0.84	0.8432761548	0.1273492498
0.87	0.8736815751	0.1260537923
0.90	0.9041248962	0.1246987063
0.93	0.9346091057	0.1232820254
0.96	0.9651374824	0.1218016005
0.99	0.9957236382	0.1202550774
1.02	1.026341568	0.1186398712
1.05	1.057025710	0.1169531363
1.08	1.087771014	0.1151917307
1.11	1.118583031	0.1133521732
1.14	1.149468013	0.1114305936
1.17	1.180433046	0.1094226707
1.20	1.211486204	0.1073235584
1.23	1.242636747	0.1051277945
1.26	1.273895371	0.1028291875

1.29	1.305274527	0.1004206756
1.32	1.336788827	0.09789414705
1.35	1.368455590	0.09524021012
1.38	1.400295553	0.09244789273
1.41	1.432333847	0.08950424445
1.44	1.464601342	0.08639379799
1.47	1.497136555	0.08309782514
1.50	1.529988417	0.07959328118
1.53	1.563220436	0.07585126184
1.56	1.596917171	0.07183466498
1.59	1.631194782	0.06749448803
1.62	1.6662190202	0.06276363911
1.65	1.702239730	0.05754584720
1.68	1.739657262	0.05169387118
1.70	1.765707041	0.04732524086
1.71	1.779182317	0.04496075797
1.72	1.793039080	0.04244974994
1.73	1.807364863	0.03976446865
1.74	1.822282393	0.03686685303
1.75	1.837972158	0.03370217972
1.76	1.854717304	0.03018657256
1.77	1.873065359	0.02617902980
1.78	1.893809294	0.02140500437
1.79	1.919702711	0.01515674821
1.80	1.978728657	0

Appendix C: Scientific Data Tables

Table 1: Lifting Power of Aerostatic Gases at 0°C and 1.013×10^5 Pa

Lifting Gas	Properties	Density ρ [kg/m³]	Lifting Force [N]
Hydrogen H ₂	flammable, extremely volatile	0.0899	11.80
Helium He	inert	0.1785	10.94
Water Vapor	at 150°C	~0.55	~7.35
Methane	combustible	0.717	5.650
Hot Air	at 100°C	~0.95	~3.35
Air	23% O ₂ , 76% N ₂ , 1% Ar	1.293	0

Table 2: The Beaufort Scale

Wind Scale	Velocity v [m/s]	Description of the Troposphere
0	0 - 0.6	perfectly calm lull
1	0.6 - 1.7	smoke climbs almost vertically
2	1.7 - 3.3	slight leaf agitation
3	3.3 - 6.2	small leaves are moved
4	6.2 - 7.4	moderate pennants are stretched, small branches are slightly moved
5	7.4 - 9.8	larger branches are slightly moved
6	9.8 - 12.4	larger branches are greatly moved
7	12.4 - 15.2	stiff weaker tree trunks are moved
8	15.2 - 18.2	large trees are moved
9	18.2 - 21.5	storm - small objects are overturned
10	21.5 - 25.1	storm - trees sway mightily
11	25.1 - 29.0	storm - trees uprooted, cars overturned
12	>29.0	hurricane - devastating effects

Table 3: The Standard Atmosphere (ISA)

Altitude h [m]	Temperature t [°C]	Pressure p [mbar]	Density of Air ρ [kg/m ³]
0	15.00	1013.25	1.225
100	14.35	1001.29	1.214
200	13.70	989.44	1.202
300	13.05	977.71	1.191
400	12.40	966.09	1.179
500	11.75	954.59	1.168
600	11.10	943.19	1.156
700	10.45	931.91	1.145
800	9.80	920.73	1.134
900	9.15	909.66	1.123
1000	8.50	898.70	1.112
1200	7.20	877.11	1.090
1400	5.90	855.93	1.069
1600	4.60	835.17	1.048
1800	3.30	814.83	1.027
2000	2.00	794.88	1.007
2200	0.70	775.33	0.987
2400	-0.60	756.17	0.967
2600	-1.90	737.40	0.947
2800	-3.20	719.01	0.928
3000	-4.50	700.99	0.909
3200	-5.80	683.33	0.891
3400	-7.10	666.04	0.872
3600	-8.40	649.11	0.854
3800	-9.70	632.53	0.835
4000	-11.00	616.28	0.819
4500	-14.25	577.06	0.777
5000	-17.50	540.07	0.736
5500	-20.75	504.93	0.697
6000	-24.00	471.67	0.660
6500	-27.25	440.20	0.624

Appendix D: The Zeppelins

	LZ 1 (1900)
	LZ 3 (1906)
	LZ 5 (1909)
	LZ 6 (1909)
	LZ 8 (1911)
	LZ 10 (1911)
	LZ 13 (1912)
	LZ 14 (1912)
	LZ 18 (1913)
	LZ 21 (1913)
	LZ 23 (1914)
	LZ 25 (1914)
	LZ 26 (1914)
	LZ 36 (1915)
	LZ 40 (1915)
	LZ 59 (1915)
	LZ 62 (1916)
	LZ 91 (1917)
	LZ 94 (1917)
	LZ 95 (1917)
	LZ 100 (1917)
	LZ 104 (1917)
	LZ 113 (1918)
	LZ 120 (1919)
	LZ 127 (1928)
	LZ 129 (1936)

Dimensions of the airships built in Friedrichshafen between 1900 and 1936. Over all, 129 Zeppelins were built.

Bibliography

Primary Sources by the Authors

The Design and Construction of the Radio Controlled Airship "Simon". Zürich: 1997.

The Airship "Simon". Film. Zürich 1997.

The Airship "Simon".

<http://ourworld.compuserve.com/homepages/mo78> (11/1997).

Books

Airship Design and Operation – Present and Future. Volume I + II. London: The Royal Aeronautical Society, 1986.

Ayres, Frank jr. Differential- und Integralrechnung. London: McGraw Hill, 1975.

Bentele, Eugen. Ein Zeppelin-Machinist erzählt. Meine Fahrten 1931 – 1938. Friedrichshafen: Robert Gessler GmbH & Co. KG, 1992.

Botting, Douglas. Die Luftschiffe. Eltville am Rhein: Bechtermünz Verlag GmbH, 1993.

Deighton, Len. Airshipwreck. New York: Holt, Rinehart and Winston, 1979.

DeLaurier, James D., Schenck, David M. Airship Dynamic Stability. AIAA Paper No. 19-1591, AIAA 3th Lighter-than-Air Systems Conference, 1979.

DeLaurier, James D., and Hui, Kenneth Chiu K. An Analytical Investigation of Airship Survivability in Atmospheric Turbulence. Research Report No. 82. Toronto: University of Toronto and York University, 1981.

DeLaurier, James D., and Evans, John R. The Shenandoah Flies Again: A Computer Simulation. AIAA Paper No. 81-1325, AIAA 4th Lighter-than-Air Systems Conference, 1981.

Dick, Harold G. Graf Zeppelin and the Hindenburg. The Golden Age of the Great Passenger Airships. Washington, D.C.: Smithsonian Institution Press, 1992.

Dubs, Fritz. Aerodynamik der reinen Unterschallströmung. Basel: Verlag Birkhäuser, 1954.

Eckener, Hugo. Im Luftschiff über Länder und Meere. Flensburg: Verlagshaus Christian Wolff, 1959.

Englmann, Felicia. "Zeppeline – Die Rückkehr der Riesen." P.M.-Perspektive. 97/047: 52–56.

Hallmann, W. and Suttrop F., ed. Hot Air Aerostatic Vehicle Technology. Aachen: German Aerospace Society, 1991.

Kohlenstoff- und aramidfaserverstärkte Kunststoffe. VDI-Gesellschaft Kunststofftechnik. Düsseldorf: Verlag des Vereins Deutscher Ingenieure, 1977.

Lagrange, Mario J. B. Aerodynamic Forces on an Airship Hull in Atmospheric Turbulences. University of Toronto: Institute for Aerospace Studies, 1984.

Nicholls, Robert. Composite Construction Materials Handbook. Englewood Cliffs: Prentice-Hall, 1976.

Prill, Otto. Die Fehler des starren Systems und die lenkbaren Luftschiffe der Zukunft. Eine öffentliche Aussprache mit dem Grafen von Zeppelin. Hamburg: Im Selbstverlag des Verfassers, 1908.

Schaum, Daniel, Van der Merve, Carel W. Duffin, William J. Physik. Schaum – Überblicke, Aufgaben. Frankfurt a. M.: McGraw-Hill Book Company, 1990.

- Schiller, Hans von. Zepplin. Aufbruch ins 20. Jahrhundert. Bonn: Kirschbaum Verlag, 1988.
- Smith, Richard K. The Airships Akron and Makon. Flying Aircraft Carriers of the United States Navy. Annapolis: Naval Institute Press, 1965.
- Zepplin, Ferdinand Graf von. Die Luftschiffahrt. Dem heutigen Stande der Wissenschaft entsprechend dargestellt. Stuttgart: Franksche Verlagshandlung, 1908.

World Wide Web Sites

- Aircraft of the Royal Air Force. 1997.
<http://www.ecafe.org/~paul/paul.htm>
 (4 May 1997).
- Airship Science. 1996.
<http://www.dirigibles.fr.eu.org/physics.html>
 (15 Dec. 1996).
- Bell Boeing V-22 Osprey. 1997.
<http://www.bellhelicopter.textron.com/lowrez/cn/tr/v22.html>
 (4 May 1997).
- Boeing CH-47D Chinook Helicopter. 1997.
<http://www.hangkong.ac.kr/univers/dsg.chinook.html>
 (4 May 1997).
- The Complete RC Webdirectory Index.. 1997.
<http://www.uoguelph.ca/~antoon/websites/rc.html>
 (12 Jan. 1997).
- Design and Build Your Own Airship. 1996.
<http://www.amherst.edu/~rkescher/airship.html>
 (15. Dec. 1996).
- Gasser Airships. 1997.
http://utopia.intelmatique.fr/~mpj/airships/RC_Models/Previous/Gasser/index.html
 (4 May 1997).
- General R/C Airship Contruction Guidelines. 1996.
http://utopia.intelmatique.fr/~mpj/airships/RC_Models/rc_notes.html
 (15 Dec. 1996).
- The Home Page for Lighter-Than-Air Craft. 1996.
<http://spot.colorado.edu/~dziadeck/airship.html>
 (15 Dec. 1996).
- The Kanehira Corporation. 1997.
http://kanehira.mes.co.jp/Tamaship/trip/products/pro12_e.html
 (4 May 1997).
- RC Airships and Blimps. 1997.
<http://www.amherst.edu/~rkescher/rcblimp.html>
 (4 May 1997).
- Remotely-Piloted Airships (RPAs). 1997.
http://utopia.intelmatique.fr/~mpj/airships/RC_Models/RC_Models
 (4 May 1997).
- Rotating Arm Facility. 1997.
<http://www50.dt.navy.mil/facilities/RotArm.html>
 (4 May 1997).

SECAP Solar Airship Program. 1996.

<http://minerva.acc.virginia.edu/~secap.html>
(15 Dec. 1997).

The Sikorsky Home Page. 1997.

<http://www.sikorsky.com>
(4 May 1997).

Das Solarluftschiff Lotte. 1997.

<http://www.isd.uni-stuttgart.de/arbeitsgruppen/airship/lotte.html>
(12 Jan. 1997).

X-29 Fact Sheet. 1997.

http://www.dfrf.nasa.gov/PAO/FactSheets/X_29FACTS.html
(4 May 1997).

Multimedia Sources

Advanced Tactical Fighter. Jane's Combat Simulations. Electronic Arts, 1996.

The Hindenburg. Film. 126 min, 1975.

Das Luftschiff-Spektakel. Film. Format NZZ, 1996.

New Grolier Multimedia Encyclopedia. Release 6. Version 6.03. Grolier Electronic Publishing, 1993.

Zurück zum Zeppelin. Film. Format NZZ, 1996.

Sources for Figures and Tables

All the illustrations, pictures, and tables of this report were made by the authors except for those indicated below.

Part I

Fig. 1: Types of Lighter-Than-Air Aircraft. Airship Design and Operation, Volume II.

Fig. 2: The Lift Logo. Airship Design and Operation, Volume I.

Part II

Appendices

B: Table 1: Lifting Power. Airship Science.

B: Table 2: The Beaufort Scale. Airship Science.

B: Table 3: The Standard Atmosphere (ISA). Airship Science.

C: The Zeppelins. Zeppelin. Aufbruch ins 20. Jahrhundert.